



EK07

INTRODUCTION

This easy-to-use kit provides a platform for the evaluation of PWM amplifier circuits using the SA07 pin-out. With ample breadboarding areas it is flexible enough to analyze a multitude of standard or proprietary circuit configurations. Critical connections for power supply bypassing, compensation and current limiting are pre-wired. Components not usually readily available in engineering labs are provided. External connection to the evaluation kit can be made via the terminals at the edge of the circuit board. These terminal pads are suitable for standard banana jacks or direct soldering of wires. The schematic is shown in Figure 1.

PARTS LIST

Part #	Description, Vendor	Quantity
CLAMP02	Mounting clip, Apex	1
HS21	Heat sink, Apex	1
EVAL18	PC Board, Apex	1
TWO9	Thermal washer, Apex	1 Box/10 each
OX7R105KWN	Capacitor, Novacap 1825B105K201N	2
CRS01	Resistor, Caddock MP725-0.10-1%	2
CRS02	Resistor, Caddock MP725-0.05-1%	2

ASSEMBLY

See Figure 3.

1. Solder the surface mount ceramic capacitors to the DUT side of the circuit board at CVs and CVcc.
2. Select a current limiting resistor from the two values provided. See the product data sheet for information on how to select a value. Apply a thin coating of thermal grease to the back of the resistors. Press the resistor body onto the circuit board foil at positions Ra and Rb and solder the leads.
3. Assemble the amplifier, thermal washer and heat sink to the circuit board as illustrated in Figure 1. As a last step push the clip through the heat sink and circuit board until it locks. Solder the amplifier pins to the circuit side of the circuit board.
4. The four holes at the corners of the circuit board are for mounting #6 standoff spacers if desired.
5. Add other components as necessary to complete your application circuit.

BEFORE YOU GET STARTED

- * All Apex amplifiers should be handled using proper ESD precautions.
- * Always use thermal grease between the amplifier and heat-sink.
- * Always use adequate power supply bypassing.
- * Do not change connections while the circuit is powered.
- * Initially set all power supplies to the minimum operating levels allowed in the device data sheet.

FIGURE 1.

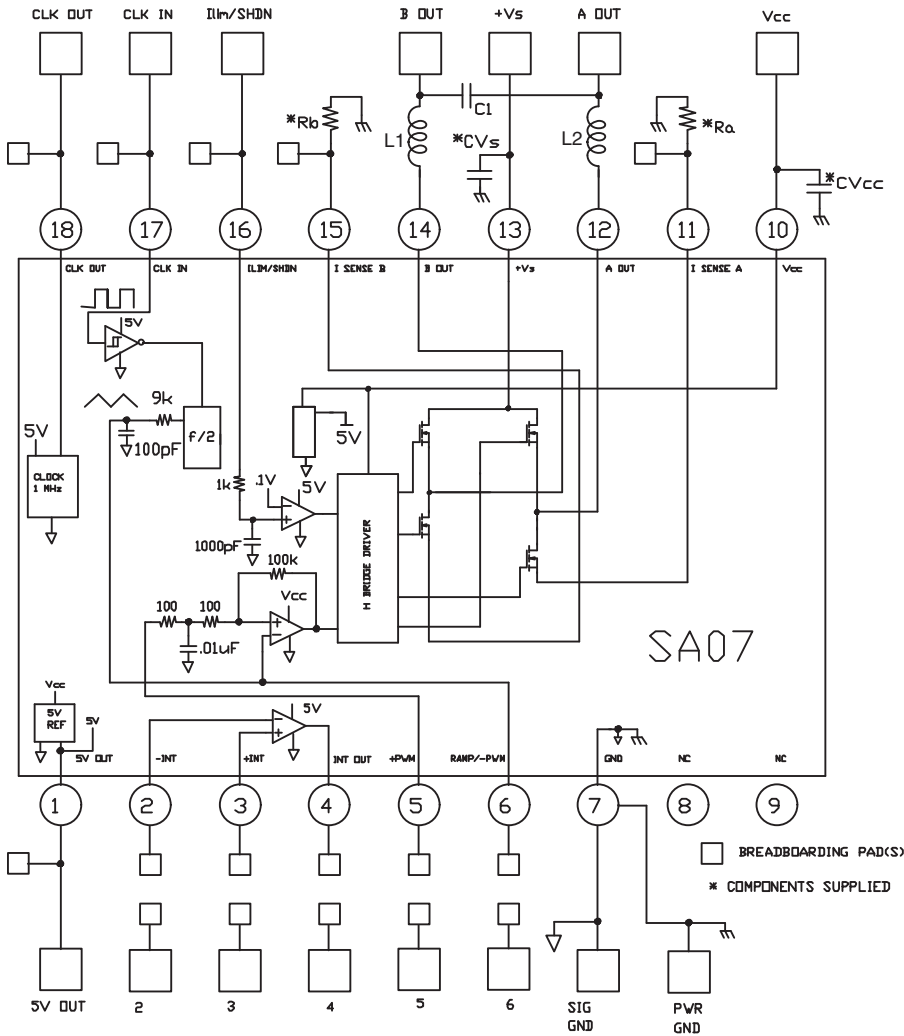

Figure 1 shows the schematic of the evaluation kit's pre-wired connections. Components supplied with the kit are marked with an asterisk (*). All other connections are made via the bread-boarding areas of the circuit board.

FIGURE 2.

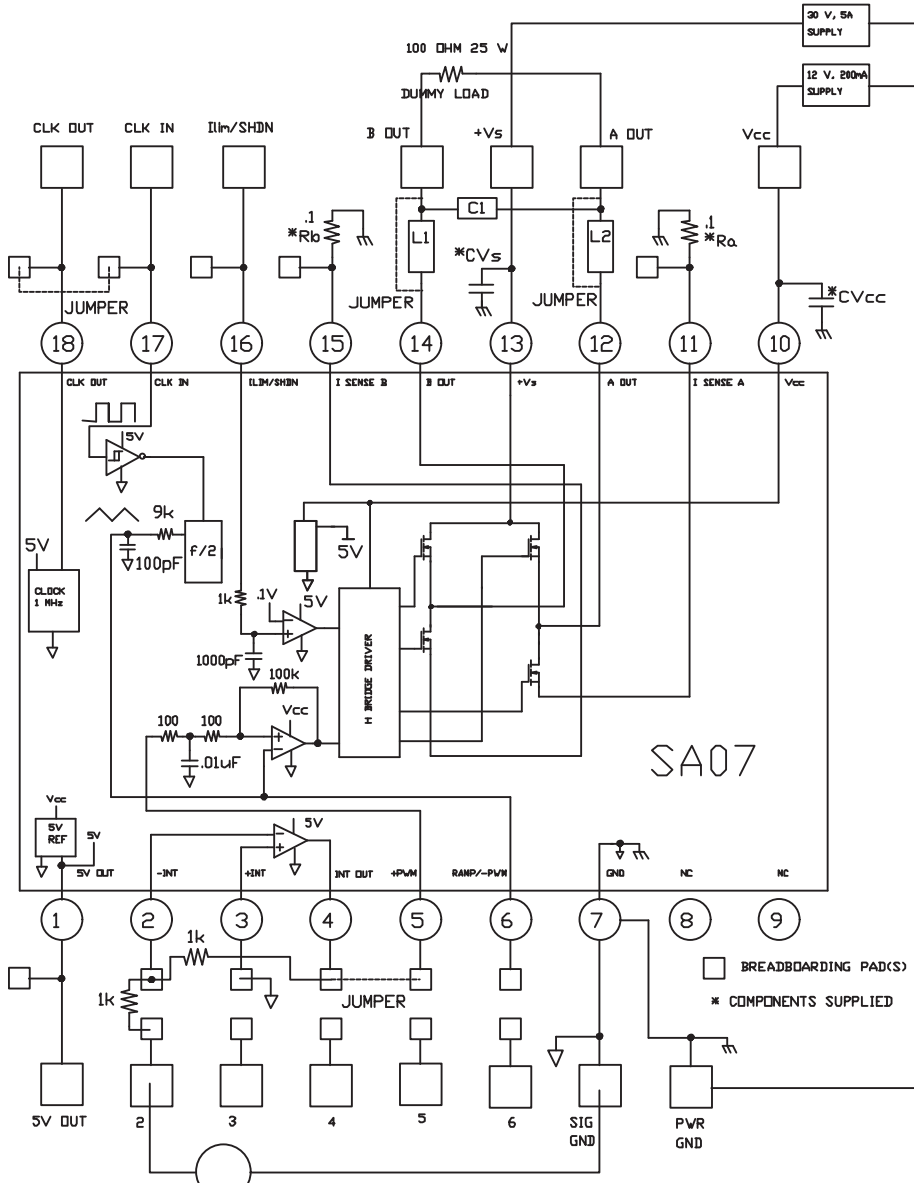

Figure 2 shows a suggested simple test circuit that you can build to gain a familiarity with the evaluation kit as well as the amplifier. At the A OUT or B OUT pads relative to power ground you should observe a square wave with a frequency of approximately 500kHz, 30V p-p which is being modulated from approximately 0 to 100 % duty cycle at a rate of 1 Hz.

FIGURE 3. PCB

